

4. For smaller varieties of maize a smaller square is cut out, and for larger varieties a larger square can be removed.
5. The dry maize cob is held in one hand and the sheller in the other. Push the end of the cob into the large hole in the sheller, and rotate the sheller so that the ridges pull out the grain. When the cob is half way through, turn it round and start at the other end.

(Information from: Pinson, G S (1977) A Wooden hand-held maize sheller. *Rural Technol. Guide, Trop. Prod. Inst.*, no 1, 12 pp)

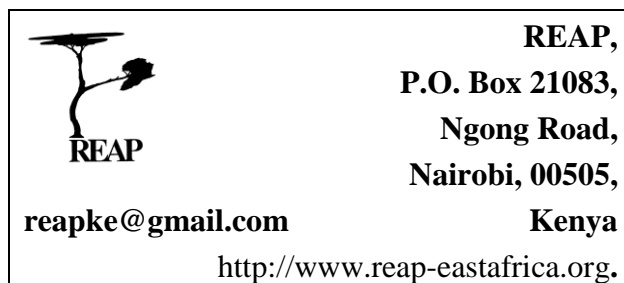

MAIZE SHELLER

Where maize is grown for home consumption of the dried grain, the seeds are often removed from the cob by hand. This can be a tedious job, which is unpleasant on the hands.

A simple hand held sheller can be made by any carpenter using a small piece of hardwood. The wood needs to be of good quality, so that it will not crack or split easily.

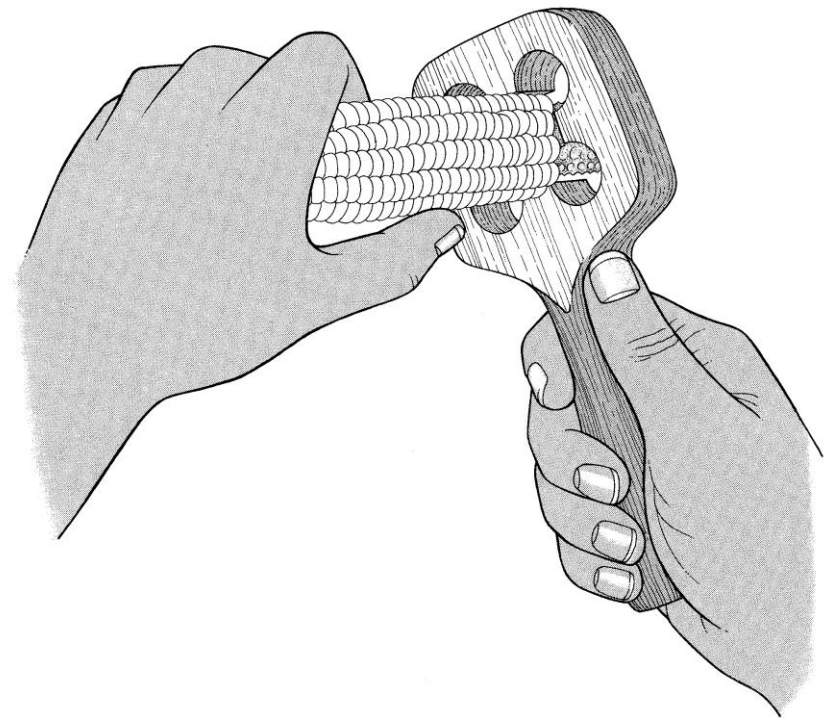

1. A piece of knot free hardwood about 19 cm X 7½ cm and about 3 cm thick, is shaped so that it has a rounded square head and a handle that is comfortable to hold, as in the diagram.

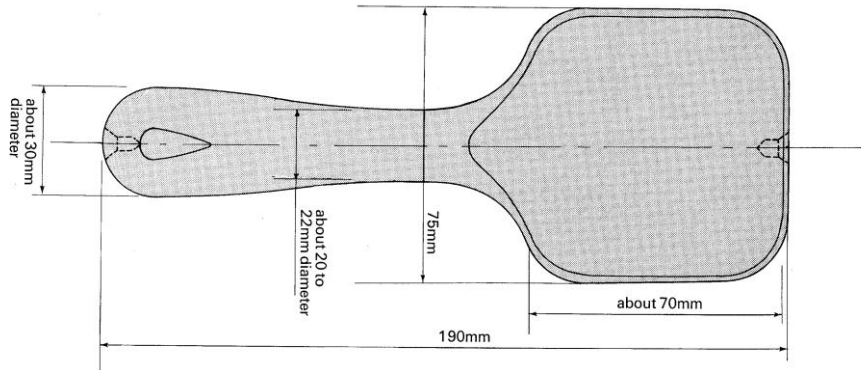

2. Four holes are drilled in the square head in a 3 cm square. These holes are enlarged using a 7/8" or 22 mm diameter bit.

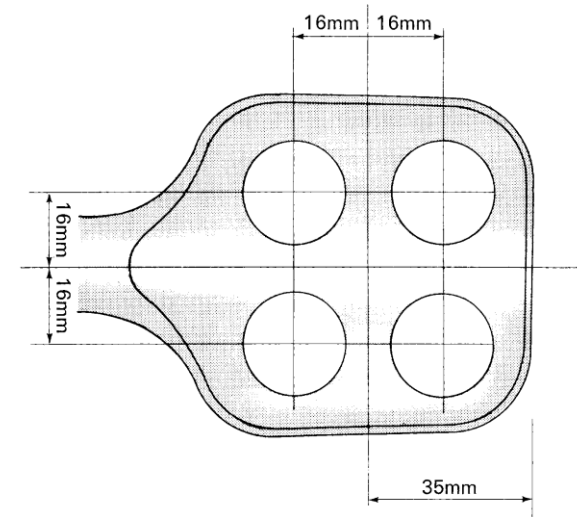
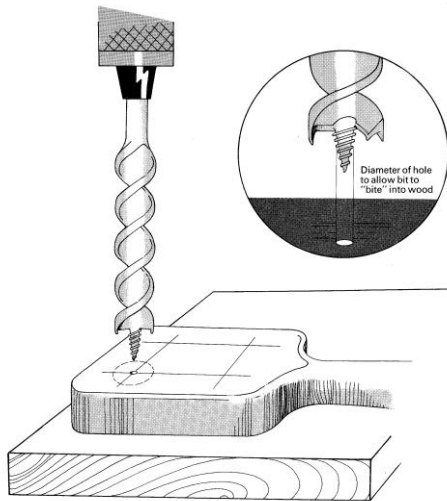

3. The wood between these holes is then cut away with a chisel to make a square in the middle of the block as in the diagram.

